

FIRE HYDRANT BOLLARD PROTECTION- TYPE C

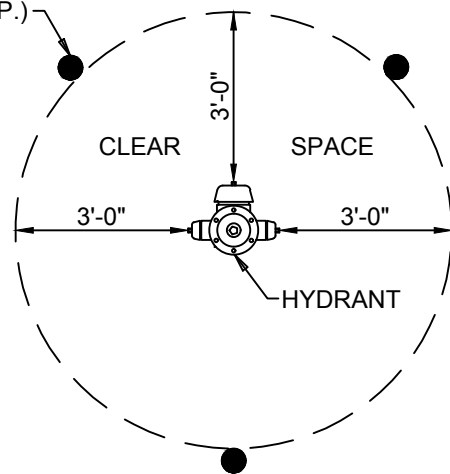

FIRE HYDRANT BOLLARD PROTECTION- TYPE B

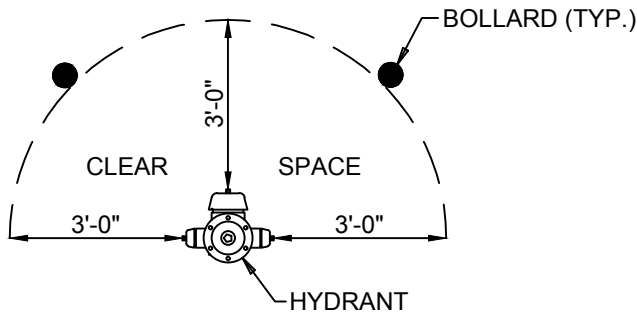

FIRE HYDRANT BOLLARD PROTECTION- TYPE A

NOTE:  
PROTECTIVE BOLLARDS SHALL BE PLACED SO THERE IS NO INTERFERENCE WITH THE OPERATION OF THE FIRE HYDRANT OR IT'S AUXILIARY VALVE.

TYPE 47-B CONCRETE REQUIRED  
VOLUME-1.4 CU. FT.  
FILLED WT.-APPROX. 235 LBS. EA.

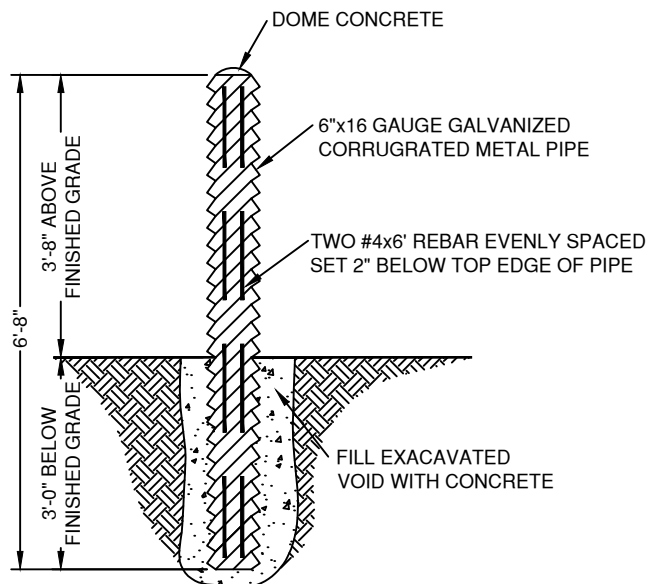

FIRE HYDRANT BOLLARD DETAIL

THIS DOCUMENT WAS  
ORIGINALLY SEALED AND  
ISSUED BY RYAN L. SCHMITZ  
E 3818, ON 11-15-2019. THIS  
MEDIA SHOULD NOT BE  
CONSIDERED A CERTIFIED  
DOCUMENT, AND SHOULD BE  
USED FOR REFERENCE ONLY.