

Revisions
7/2007 P.F.G.

SILT FENCE CULVERT INLET PROTECTION

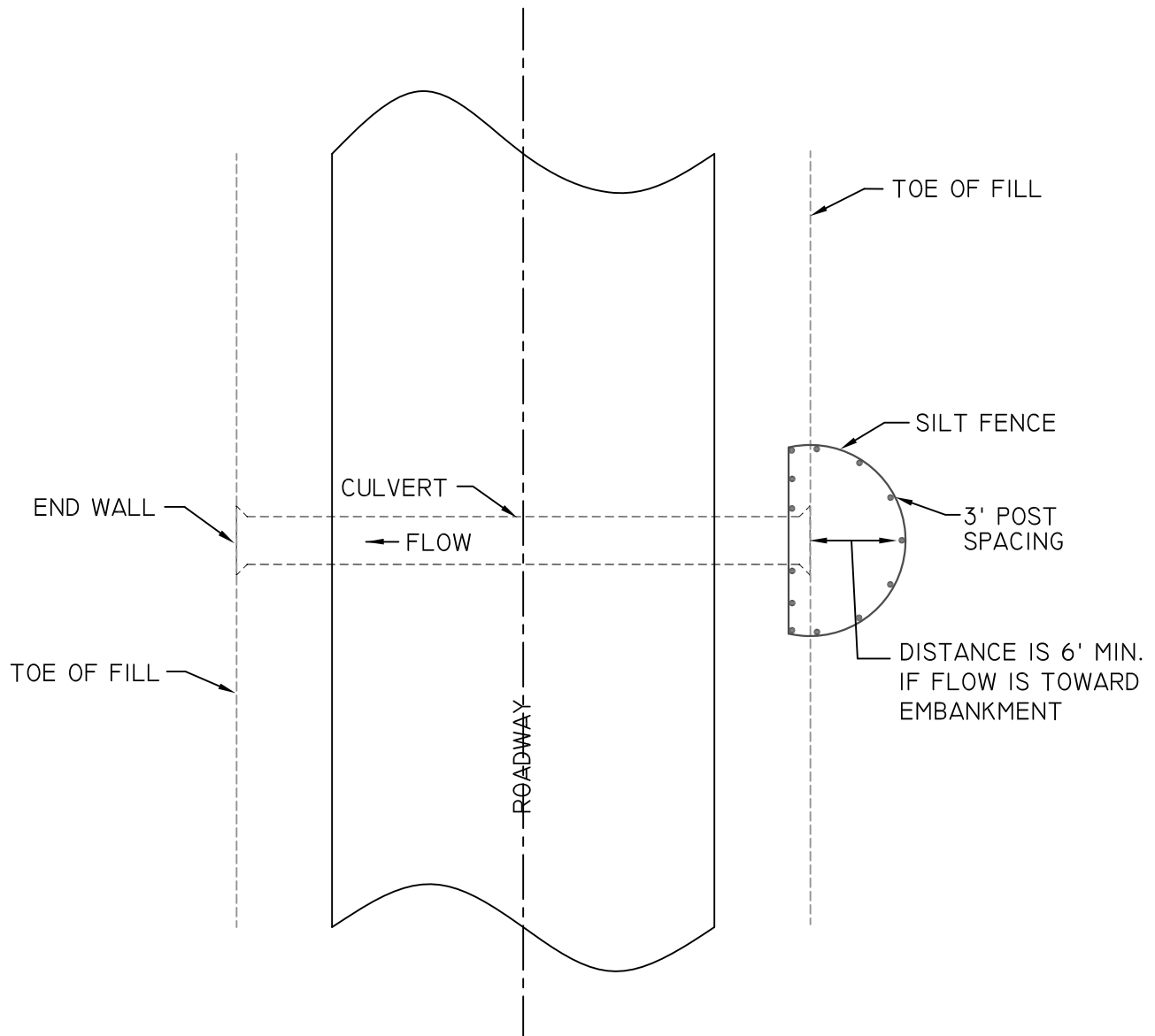

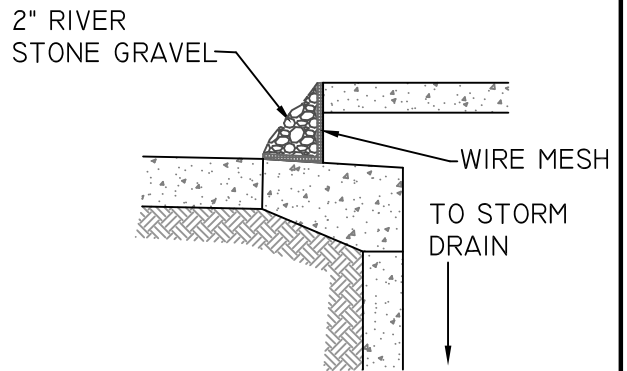
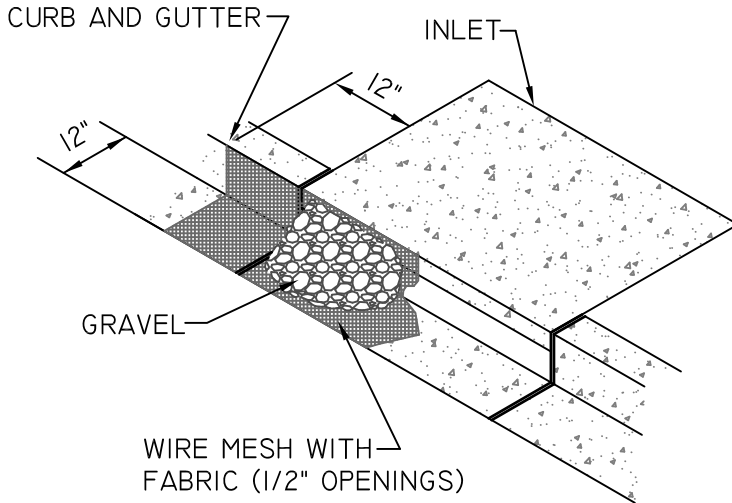

GRAVEL CURB INLET SEDIMENT FILTER

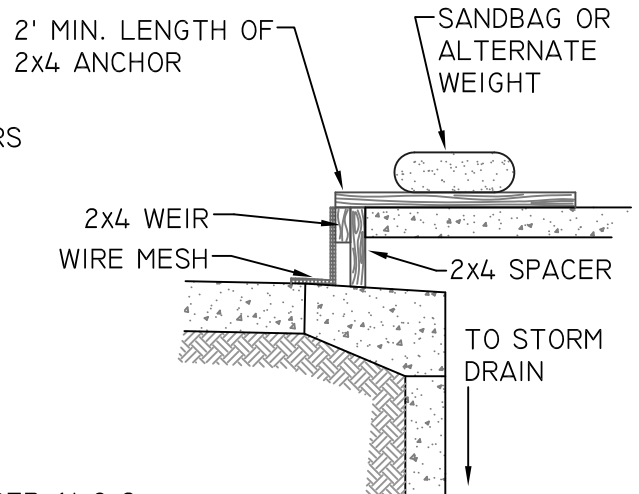
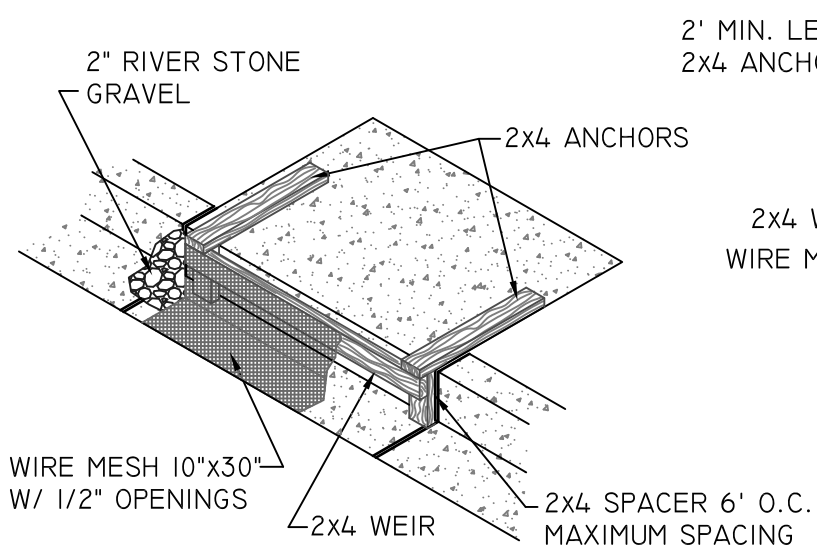

CURB INLET PROTECTION WITH 2x4 WOODEN WEIR

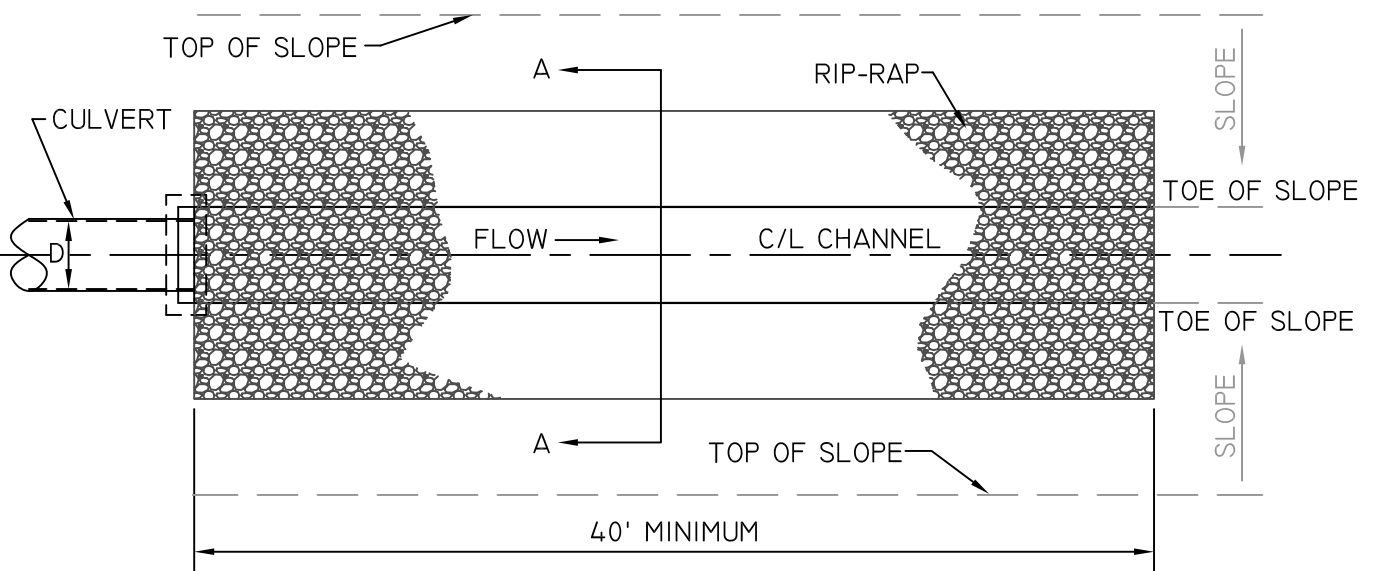

PLAN VIEW

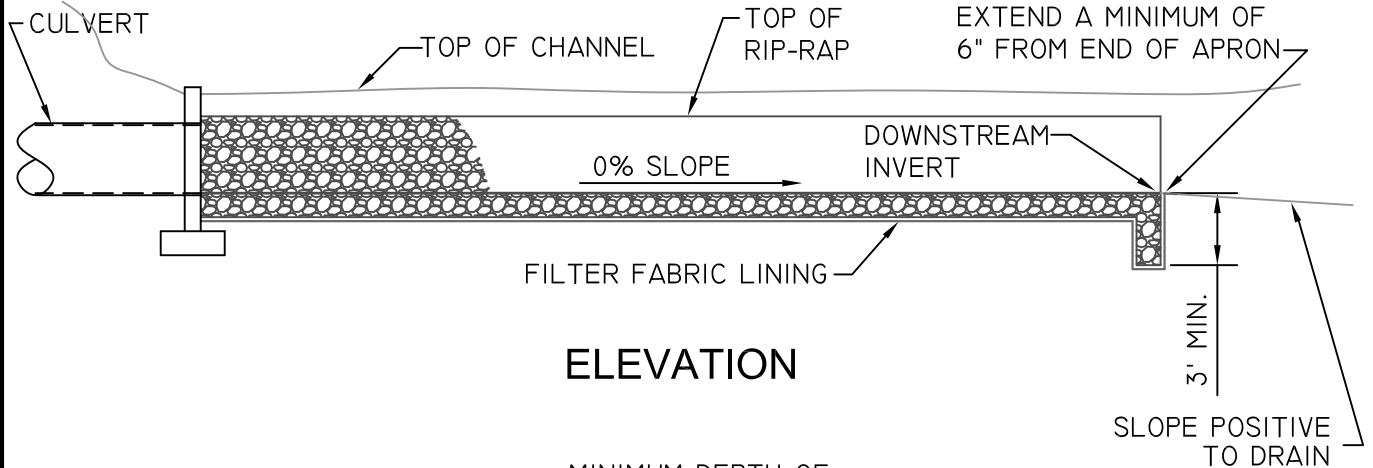

ELEVATION

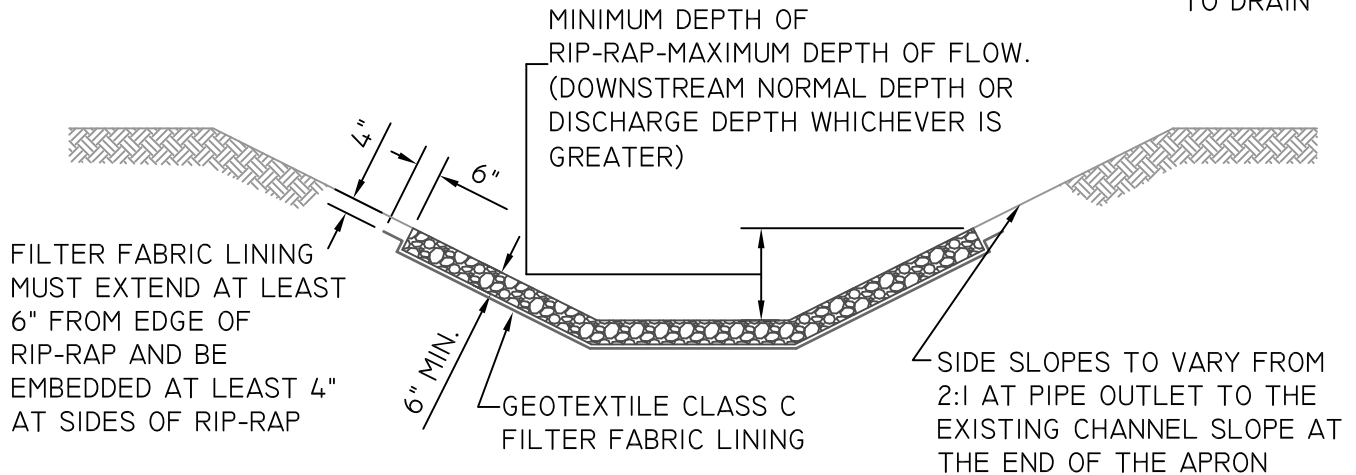

SECTION A-A

